

RINAMALAYAN

INFORMATION STRATEGIC & MANAGEMENT PLAN 2024

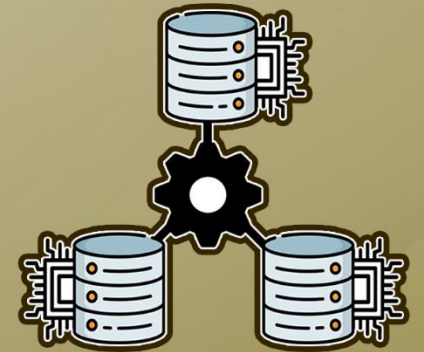



Republic of the Philippines
Province of Oriental Mindoro
MUNICIPALITY OF PINAMALAYAN

MUNICIPAL INFORMATION STRATEGIC AND MANAGEMENT PLAN 2024

PROOF OF RECEIPT



OFFICE/AGENCY/DIVISION	RECEIVED				SIGNATURE
	ON:		BY:		
	Date	Time	Printed Name	Position/Designation	
Municipal Mayor's Office	6-9-23	8:37	MAR MENDOZA	AM	
Technology for Education, Employment, Entrepreneurs, and Economic Development (Tech4Ed)	6-9-23	8:40	JULIE ANN MAE LUARCA	Tech4ED Asst. manager	
Municipal Vice Mayor's Office and the Sangguniang Bayan	5-31-2023	4:55	JASMIN G. TUGADI	A-A-2	
Municipal Administrator's Office	6-7-23	2:37	MELBOY P. MENDOZA	A-A-III	
Municipal Planning and Development Office	5-31-23	4:50	GERALD M. DUCATEL	ITA	
Municipal Budget Office	6-7-23	3:06	MARIA ANNA ABULCAN	BAW	
Municipal Accounting Office	6/8/23	11:15	MJ FUENTES	COI	
Municipal Treasury Office	6-7-23	4:12	BABYLON L. SENIO	A-A-11	
Municipal Local Government Operations Office	6-9-23	9:57	BARRAN OMP	BAW	
Provincial Budget Office	6-9-23	3:06	MARIA ANNA ABULCAN	BAW	
Commission on Audit (COA)	6/8/23	11:15	MJ FUENTES	COI	



CONTENTS

- **Messages**
 - **Municipal Mayor**
 - **Municipal Vice Mayor**
- **Acknowledgement**
- **Approval / Adoption**
 - **Sangguniang Bayan (SB) Resolution No. 128-2023**
 - **Municipal Development Council (MDC) Resolution No. 02-2023**
- **Vision Statement**
- **Mission Statement**
- **Strategic Thrusts and Development Priorities**
- **Core Values**
- **Pinamalayan Brief Profile**
- **Information Strategic and Management Plan (ISMP) 2024**

OFFICE OF THE MUNICIPAL MAYOR



MESSAGE



The Local Government Unit of Pinamalayan under our leadership, remains focus, steady and firm to our sworn commitment to Pinamaleños. We have utilized our funds and resources in achieving our noble commitment to people. Programs, projects and activities are well aligned and attuned to the demands of the public. We have remained committed to our mission of reaching out to the most vulnerable members of society. As a result, we must level up, improve, and modify all of our initial activities in order to satisfy the unique requirements of our people while also adapting to the demands of a changing world.

My fellow Pinamaleños, it is with great pride and honor to present and dedicate this compilation of Thematic Plans and Programs 2024, a navigational plan towards the Local Government's developmental framework and program intervention for the Fiscal Year 2024.

This plan of action reflects our expectations for conquering challenges and moving forward. It contains the programs/projects/activities streamlined for the coming year from a long master list of projects generated through sectoral consultation. Furthermore, with the unwavering support and active participation of all stakeholders, we can vouch that no sector is being left behind and guarantee the inclusivity of all programs.

Also, our heartfelt gratitude goes to the dedicated men and women of these municipality who place their best efforts to come up with this plan.

Hail Pinamalayan and all its people- ang Bayan ng Bahaghari, Bayang Pinagpala. Pilipinas, Pinamalayan Naman!

HON. ARISTEO APASAN BALDOS, JR.
MUNICIPAL MAYOR

OFFICE OF THE MUNICIPAL VICE MAYOR



MESSAGE



HON. RODOLFO M. MAGSINO
MUNICIPAL VICE MAYOR

Warmest greeting!

Success is no accident. It takes a lot of hard work, perseverance, learning, studying, sacrifice, and most of all, love of what you are doing or learning to do.

The municipality of Pinamalayan aims to become a sustainable place to live for every Pinamaleños. Planning and implementation are the best tool in making success. Thematic planning is an important activity of the Local Government Unit with the objective of building a more progressive municipality.

In this activity, the Local Chief Executive together with the Vice Mayor, Sangguniang Bayan Members, Department Heads, Chief of offices, and the representatives from different sectors joined together in a group discussion and identifying different programs, projects and activities that we believe needed to be implemented and can make an impact in the society.

Through inquiries, careful studies, researches and workshops, we will be able to sustain and meet the demands of the ever-changing time. Long term solutions, programs, projects and activities to be implemented are relevant and beneficial to the people. We cannot stop the passing time, but we have the power to define it.

With our collaborative efforts we can make Pinamalayan a sustainable place to live in. Let us work together and win as one. With the help of the Almighty, hand in hand, we can achieve what we are dreaming for our beloved Pinamalayan.

"Today's progress was yesterday's plan" - Anonymous

ACKNOWLEDGEMENT



In the spirit of unity towards progress, deepest appreciation is hereby conveyed to the various stakeholders and institutions in our municipality such as the National Government Agencies, Barangay Government Units, Private Sector, Civil Society/Non-Governmental Organizations, the Legislative Department and the Executive Department of the Municipal Government of Pinamalayan for the unqualified support and participation in the preparation of INFORMATION STRATEGIC AND MANAGEMENT PLAN (ISMP) 2024 which was completed and packaged by the:

MUNICIPAL PLANNING AND DEVELOPMENT OFFICE

GENERAL PUBLIC SERVICES

ROMEL T. MARAYAN *Development Management Officer II
Sector Coordinator*

JAN-NEIL H. EVANGELISTA *Senior Administrative Assistant II
Sector Coordinator*

PRINCESS EUNICE L. DEL VALLE *Project Development Officer I
Sector Coordinator*

SOCIAL SERVICES

EnP VIRGILIO M. KING *Project Development Officer III
Sector Coordinator*

JOHN ERIC G. MONDOÑEDO *Planning Assistant
Sector Coordinator*

MA. LORRAINE F. FESTIN *Project Evaluation Assistant
Sector Coordinator*

ECONOMIC SERVICES

EnP. ORLEX H. MARAYAN *Development Management Officer IV / Asst. to the MPDC
Sector Coordinator*

FREDELINO A. TORIANO, JR. *Planning Officer II
Sector Coordinator*

MARIANNE L. LUARCA *Administrative Aide II
Sector Coordinator*

OTHER SERVICES

EnP. ORLEX H. MARAYAN *Development Management Officer IV / Asst. to the MPDC
Sector Coordinator*

JAYSON M. MAUPAY *Administrative Assistant I
Sector Coordinator*

ADMINISTRATIVE AND TECHNICAL SUPPORT SERVICES

RUTH D. MALING *Administrative Officer IV
Logistic In-Charge*

PHIL JOSEPH L. GALANG *Information Technology Assistant
Technical Support Staff*

GERALD M. DULATRE *Information Technology Assistant
Administrative Support Staff*

MARY JOY R. SALENDREZ *Administrative Aide III
Administrative Support Staff*

ROSELLE H. LABRADOR *Administrative Aide III
Administrative Support Staff*

EDEN M. HERNANDEZ *Administrative Aide II
Administrative Support Staff*

We are truly grateful as we commend the invaluable involvement of all concerned functionaries and Elective Officials by way of sharing their time, efforts and knowledge. As such, we are very thankful to the Municipal Development Council (MDC) Officials and Members, especially to the Chairpersons and Members of the Functional/Sectoral Working Committees for exerting tireless and selfless efforts that made possible the successful completion of the formulation process.

Above all, let us praise and thank the Almighty for His guidance as we are all His stewards in bringing about excellence in local governance.

THANK YOU AND GOD BLESS!!!

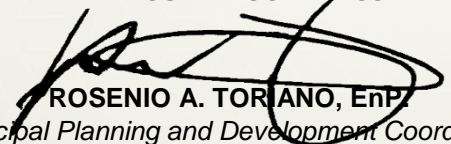
ROSENIO A. TORIANO, EnP
Municipal Planning and Development Coordinator



The Municipal Planning and Development Office
Telefax: (043) 738 - 4632
E-mail Address: mpdo.pin@gmail.com / mpdo@pinamalayan.gov.ph
Our Website: www.pinamalayan.gov.ph



MUNICIPAL APPROVAL INSTRUMENTS

- **THEMATIC PLANS AND PROGRAMS (TPP) 2024**
 - **SANGGUNIANG BAYAN (SB) RESOLUTION NO. 128-2023**
 - **MUNICIPAL DEVELOPMENT COUNCIL (MDC) RESOLUTION NO. 02-2023**



OFFICE OF THE SANGGUNIANG BAYAN

Office of the Vice Mayor/Sangguniang Bayan, 2nd Flr. Municipal Bldg. Madrid Blvd. Zone III, Pinamalayan, Oriental Mindoro
Email Address: ucsbaybayan@pinamalayan.gov.ph Tel Nos: (043) 738-1432 (043) 284-3147

EXCERPT FROM THE MINUTES OF THE REGULAR SESSION OF THE 11th SANGGUNIANG BAYAN HELD ON MAY 22, 2023 AT SANGGUNIANG BAYAN SESSION HALL, PINAMALAYAN, ORIENTAL MINDORO.

PRESENT:

HON. RODOLFO M. MAGSINO,	Municipal Vice Mayor, Presiding officer
HON. RIO S. MERCENE,	SB Member
HON. DUNHILL MARCELO M. DELMO V,	SB Member
HON. ANGELO MARLO D. MADRID,	SB Member
HON. MAURO P. HELERA,	SB Member
HON. ANJUNE A. ZAMORA,	SB Member
HON. EDWIN G. HERNANDEZ,	SB Member
HON. JEOFFREY PAUL A. UMBAO,	SB Member
HON. NAPOLEON M. MANGARING,	SB Member
HON. JOVEN S. VELASCO,	SKMF President, SB Member
HON. ANTONIO VICTOR R. OLYMPIA,	ABC President, SB Member

RESOLUTION NO. 128-2023

A RESOLUTION APPROVING THE DIFFERENT THEMATIC PLANS AND PROGRAMS (TPP) 2024 OF THE MUNICIPALITY OF PINAMALAYAN, ORIENTAL MINDORO.

WHEREAS, Section 114 of the Local Government Code provides that the policies, programs and projects proposed by the Local Development Council shall be submitted to the Sanggunian concerned for appropriate action;

WHEREAS, the thirty-seven (37) various Thematic Plans and Programs (TPP) 2024 of the Municipality of Pinamalayan were formulated after thorough researches, series of consultations, workshops, focus group discussions and other activities involving multi-sectoral presentation, to wit:

1. GENERAL PUBLIC SERVICES SECTOR

- Municipal Peace and Order and Public Safety Plan
- Municipal Capacity Development Agenda
- Municipal Anti-Drug Abuse Action Plan
- Municipal Indicative Annual Procurement Plan
- Municipal Human Resource/Capacity Development Plan
- Municipal Revenue Generation and Mobilization Plan
- Municipal Public Financial Management Improvement Plan
- Municipal Information and Communication Technology Plan
- Municipal Information Strategic Management Plan
- Municipal People's Plan
- Municipal Public Service Continuity Plan

2. SOCIAL DEVELOPMENT SECTOR

- DILG-Endorsed Municipal Gender and Development Plan and Budget
- Municipal Annual Cultural Development Plan
- Municipal Plan for the Protection of Children
- Municipal Senior Citizens and Persons with Disability Plan
- Municipal Nutrition Action Plan
- Municipal Acquired Immune Deficiency Syndrome Plan
- Municipal Youth Development Plan
- Municipal Housing/Shelter Plan
- Municipal Ancestral Domains Sustainable Development and Protection Plan
- Municipal Plan for Health and Family Planning



OFFICE OF THE SANGGUNIANG BAYAN

Office of the Vice Mayor/Sangguniang Bayan 2nd Flr., Municipal Bldg., Madro Blvd., Zone III, Pinamalayan, Oriental Mindoro
Email Address: vicemayoroffice@pinamalayan.gov.ph Tel Nos. (043) 738-1432 / (043) 284-3147

3. ECONOMIC DEVELOPMENT SECTOR

- Municipal Climate Change Action Plan
- Municipal Poverty Reduction Action Plan
- Municipal Solid Waste Management Plan
- Municipal Forest Land Use Plan
- Municipal Watershed Management Plan
- Municipal Sustainable Area Development Plan
- Municipal Foreshore Management Plan
- Municipal Food Sufficiency Plan
- Municipal Strategic Agriculture and Fisheries Development Zone Plan
- Municipal Coconut Development Plan
- Municipal Coastal Resources Management Plan
- Municipal Commodity Investment Plan
- Municipal Tourism Development Plan
- Municipal Entrepreneurship Development Plan
- Municipal Transportation Management Plan

4. OTHER SERVICES SECTOR

- PDRRMO-Reviewed Municipal Disaster Risk Reduction and Management Plan

WHEREAS, the aforementioned TPPs were adopted on the 19th day of May 2023 by virtue of MDC Resolution No. 02-2023 and were subsequently indorsed to the Sangguniang Bayan pursuant to the Local Government Code;

WHEREAS, this august body entirely recognizes the significance of the different TPPs for 2024 in providing operational guidance and effective solution in the attainment of a progressive, self-reliant, resilient and sustainable municipality.

NOW THEREFORE, BE IT RESOLVED by the Sangguniang Bayan of Pinamalayan, Oriental Mindoro to approve different Thematic Plans and Programs (TPP) 2024 of the Municipality of Pinamalayan, Oriental Mindoro.

UNANIMOUSLY APPROVED this 22nd day of May 2023 on motion of Hon. Rio S. Mercene seconded by all Sangguniang Bayan members present.

I hereby certify to the veracity and correctness of the foregoing quoted resolution.

Certified Correct:

ATTY. MIRASOL J. SANTOS
Secretary to the Sangguniang Bayan

Attested by:

HON. RODOLFO M. MAGSINO
Municipal Vice Mayor, Presiding Officer

Approved:

HON. ARISTEO APASAN BALDOS, JR.
Municipal Mayor

MAY 31 2023



Republic of the Philippines
Province of Oriental Mindoro
MUNICIPALITY OF PINAMALAYAN

OFFICE OF THE MUNICIPAL MAYOR

Madrid Blvd., Zone III, Pinamalayan, Oriental Mindoro 5208

Email: mayorsoffice@pinamalayan.gov.ph

Telephone No. 043-284-7146

MUNICIPAL DEVELOPMENT COUNCIL RESOLUTION NO.02-2023

A RESOLUTION ADOPTING THE DIFFERENT THEMATIC PLANS AND PROGRAMS (TPP) 2024 OF THE MUNICIPALITY OF PINAMALAYAN AND FAVORABLY INDORSING THE SAME TO THE SANGGUNIANG BAYAN, THIS MUNICIPALITY FOR APPROVAL.

WHEREAS, thematic planning is a prescriptive planning tool that seeks the most effective and efficient technical solution to a generic development problem;

WHEREAS, the strategic value of thematic plans is that they provide guidance on the application of techniques and in drawing on best practices and experiences which have evolved into a benchmark standard;

WHEREAS, thematic plans provide a cost-benefit analysis of the technology against conventional techniques, define the role and responsibilities of the agency in relation to other stakeholders, identifying resource requirements and seek to outline a course of action, thereby defining a framework providing a problem-based analysis of techniques that helps ensure the relevance, sustainability and impact of technical cooperation;

WHEREAS, in order to validate priority areas for cooperation and strengthening public-private partnership, different thematic plans and programs were formulated through researches, series of consultations, workshops, focus group discussions and other activities involving multi-sectoral representation;

WHEREAS, the thematic plans and programs herein referred to include the following:

1. GENERAL PUBLIC SERVICES SECTOR

- Municipal Peace and Order and Public Safety Plan
- Municipal Capacity Development Agenda
- Municipal Anti-Drug Abuse Action Plan
- Municipal Indicative Annual Procurement Plan
- Municipal Human Resource/Capacity Development Plan
- Municipal Revenue Generation and Mobilization Plan
- Municipal Public Financial Management Improvement Plan
- Municipal Information and Communication Technology Plan
- Municipal Information Strategic and Management Plan
- Municipal People's Plan
- Municipal Public Service Continuity Plan



#FullDevolution #LocalAutonomy #LocalEmpowerment





OFFICE OF THE MUNICIPAL MAYOR

Madrid Blvd., Zone III, Pinamalayan, Oriental Mindoro 5208

Email: mayorsoffice@pinamalayan.gov.ph

Telephone No.043-284-7146

2. SOCIAL DEVELOPMENT SECTOR

- DILG-Endorsed Municipal Gender and Development Plan and Budget
- Municipal Annual Cultural Development Plan
- Municipal Plan for the Protection of Children
- Municipal Senior Citizens and Persons with Disability Plan
- Municipal Nutrition Action Plan
- Municipal Acquired Immune Deficiency Syndrome Plan
- Municipal Youth Development Plan
- Municipal Housing/Shelter Plan
- Municipal Ancestral Domains Sustainable Development and Protection Plan
- Municipal Plan for Health and Family Planning

3. ECONOMIC DEVELOPMENT SECTOR

- Municipal Climate Change Action Plan
- Municipal Poverty Reduction Action Plan
- Municipal Solid Waste Management Plan
- Municipal Forest Land Use Plan
- Municipal Watershed Management Plan
- Municipal Sustainable Area Development Plan
- Municipal Foreshore Management Plan
- Municipal Food Sufficiency Plan
- Municipal Strategic Agriculture and Fisheries Development Zone Plan
- Municipal Coconut Development Plan
- Municipal Coastal Resources Management Plan
- Municipal Commodity Investment Plan
- Municipal Tourism Development Plan
- Municipal Entrepreneurship Development Plan
- Municipal Transportation Management Plan

4. OTHER SERVICES SECTOR

- PDRRMO-Reviewed Municipal Disaster Risk Reduction and Management Plan

WHEREAS, the Municipal Development Council in full council meeting has thoroughly reviewed and objectively considered the contents and linkages of the above-named TPPs;

NOW, THEREFORE, on motion of Punong Barangay Gilbert A. Seño of Pili and duly seconded by all members present, be it . . .

RESOLVED, AS IT IS HEREBY RESOLVED, to adopt the different THEMATIC PLANS AND PROGRAMS (TPP) 2024 of the Municipality of Pinamalayan, and favourably indorsing the same to the Sangguniang Bayan for appropriate action.

UNANIMOUSLY ADOPTED this 19th day of May 2023.

#FullDevolution #LocalAutonomy #LocalEmpowerment





Republic of the Philippines
Province of Oriental Mindoro
MUNICIPALITY OF PINAMALAYAN

OFFICE OF THE MUNICIPAL MAYOR

Madrid Blvd., Zone III, Pinamalayan, Oriental Mindoro, 5208

Email: mayoroffice@pinamalayan.gov.ph

Telephone No. 043-284-7146

THE 37 BARANGAY CAPTAINS OF PINAMALAYAN:



HON. RANDY H. MOREDO
Barangay Captain, Anoling
Member



HON. EDNA L. RANILLO
Barangay Captain, Bangbang
Member

HON. ANDRES M. GANIBO
Barangay Captain, Buli
Member



HON. EUGENIO M. MANTARING
Barangay Captain, Calingag
Member

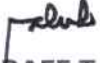

HON. JOEY C. JAMINOLA
Barangay Captain, Guinhawa
Member



HON. RICO M. BONIFACIO
Barangay Captain, Lumambayan
Member

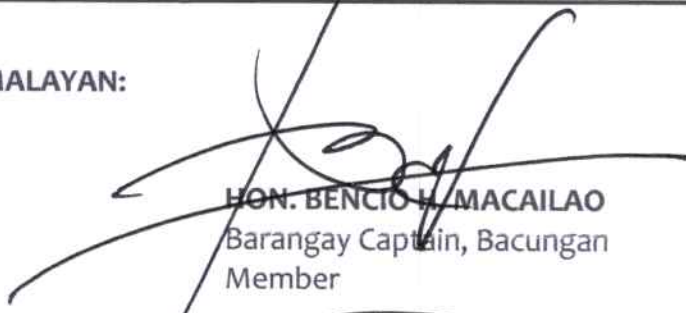

HON. MERAPE T. ALUB
Barangay Captain, Maliangcog
Member

HON. ENRICO M. CAUNCERAN
Barangay Captain, Marayos
Member

HON. ANTONIO S. MOGOL
Barangay Captain, Nabuslot
Member

HON. BENCIO H. MACAILAO
Barangay Captain, Bacungan
Member



HON. JOELITO J. PERLAS
Barangay Captain, Banilad
Member

HON. NORVEN M. ARELLANO
Barangay Captain, Cacawan
Member

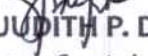

HON. DANTE H. MAZON
Barangay Captain, Del Razon
Member

HON. JOHNNY A. LOLONG
Barangay Captain, Inclanay
Member

HON. TEOFILO P. SAPUSAO
Barangay Captain, Malaya
Member

HON. JUDITH P. DE BELEM
Barangay Captain, Maningcol
Member

HON. ROMEO M. DIMAANO
Barangay Captain, Marfrancisco
Member

HON. LERMA M. MANRIQUE
Barangay Captain, Pagalagala
Member





Republic of the Philippines
Province of Oriental Mindoro
MUNICIPALITY OF PINAMALAYAN

OFFICE OF THE MUNICIPAL MAYOR

Madrid Blvd., Zone III, Pinamalayan, Oriental Mindoro 5208

Email: mayoroffice@pinamalayan.gov.ph

Telephone No. 043-284-7146

THE 37 BARANGAY CAPTAINS OF PINAMALAYAN:



HON. NOLITO A. DELA CRUZ
Barangay Captain, Palayan
Member



HON. AMADEO Q. MAGTIBAY
Barangay Captain, Pambisan Munti
Member



HON. RAUL M. MICIANO
Barangay Captain, Papandayan
Member

HON. CELSO V. MONDOÑEDO JR.
Barangay Captain, Quinabigan
Member

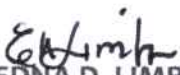

HON. HIPOLITO D. ONDOY
Barangay Captain, Rosario
Member

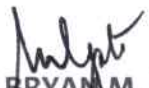

HON. MERLITA M. PANGANIBAN
Barangay Captain, Sta. Isabel
Member



HON. EDNA D. LIMBO
Barangay Captain, Sto. Niño
Member

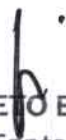

HON. ROY BRYAN M. MALAPOTE
Barangay Captain, Zone I
Member

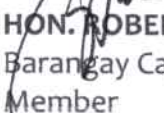

HON. FERNANDO T. RODIL
Barangay Captain, Zone III
Member



HON. ANTONIO VICTOR R. OLYMPIA
ABC President
Liga ng mga Barangay
Barangay Captain, Sta. Rita
Member

HON. LORETO E. FLORES
Barangay Captain, Pambisan Malaki
Member



HON. ROBERTO A. MICIANO
Barangay Captain, Panggulayan
Member

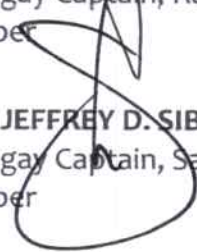

HON. GILBERT A. SEÑO
Barangay Captain, Pili
Member

HON. ARNEL F. NAMBIO
Barangay Captain, Ranzo
Member

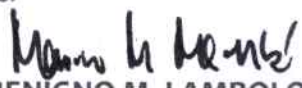
HON. JEFFREY D. SIBOBO
Barangay Captain, Sabang
Member

HON. RUFINO S. DIMAPILIS
Barangay Captain, Sta. Maria
Member

HON. BENIGNO M. LAMBOFOTO
Barangay Captain, Wawa
Member

HON. MARY FRANCIS DEOCORA M. FABIE
Barangay Captain, Zone II
Member

HON. VICTOR J. LINGON
Barangay Captain, Zone IV
Member





Republic of the Philippines
Province of Oriental Mindoro
MUNICIPALITY OF PINAMALAYAN

OFFICE OF THE MUNICIPAL MAYOR

Madrid Blvd., Zone III, Pinamalayan, Oriental Mindoro 5208

Email: mayorsoffice@pinamalayan.gov.ph

Telephone No. 043-284-7146

REPRESENTATIVES OF NON-GOVERNMENT ORGANIZATION (NGOs)

RICARDO B. DELA CRUZ

President, Bahaghari Pinamalayan, Oriental Mindoro
Federation of Tricycle Operators and Driver's
Association, Inc. (BPOMFEDTODA)
Representative to the Executive Committee

LEA S. FIEDALAN

President, Ranzo Farmer's Association
Member



EDWIN C. ANDAL

President, Kapulungan ng Sandigang Magkakarne
(KASAMA)
Member

ESTELITA M. FIEDALAN

President, Samahan ng Lingap Pamilyang
Pinamaleño (SLNPP)
Member

CECILIA L. KASILAG

President, Local Council for Women
Member

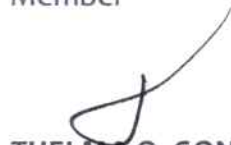

THELMA O. GONZALES

President, Kaagapay Tungo sa Maunlad na
Pamumuhay
Association of Barangay Buli
Member

GORGONIO SUMBAD

President, Samahan Kaligtangan Tadyawan
Member



LORENZA R. LOLONG

President, Young Progressive Vendors and
Vegetable Dealers and Retailers
Association of Pinamalayan Market, Inc.
(YPVVDRAPMI)
Member

BERNIE P. SEÑORIN

President, Samahang Mandaragat ng
Banilad (SAMBA)
Member



FELIX M. MAGBOO

Vice President, Pinamalayan Bahaghari
Farmer's Federation
Member

FE G. MERCENE

President, Federation of Senior Citizens of
Pinamalayan
Member

DIVINA D. MADRID

President, Pinamalayan Retired Teachers
Organization
Member

GERALD F. LUHA

President, Sandugo Rescue and Radio
Communication Group-Lima Chapter
Pinamalayan
Member

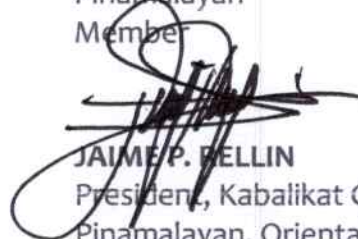

JAIME P. BELLIN

President, Kabalikat Civicom 843 Chapter
Pinamalayan, Oriental Mindoro
Member



#FullDevolution #LocalAutonomy #LocalEmpowerment





Republic of the Philippines
Province of Oriental Mindoro
MUNICIPALITY OF PINAMALAYAN

OFFICE OF THE MUNICIPAL MAYOR

Madrid Blvd., Zone III, Pinamalayan, Oriental Mindoro 5208

Email: mayoroffice@pinamalayan.gov.ph

Telephone No.043-284-7146

HON. RIO S. MERCENE

SB Member

Chairperson, Committee on Finance & Appropriations

HON. ALFONSO V. UMALI, JR.

Congressman

2nd District, Oriental Mindoro

Attested by:

ORLEX H. MARAYAN, EnP.

Development Management Officer IV
Secretary, MDC Secretariat

Certified Correct:

ROSENIO A. TORIANO, EnP.

MPDC - MGDH I
Head, MDC Secretariat

Approved:

HON. ARISTEO APASAN BALDOS, JR.

Municipal Mayor
Chairperson, Municipal Development Council





VISION

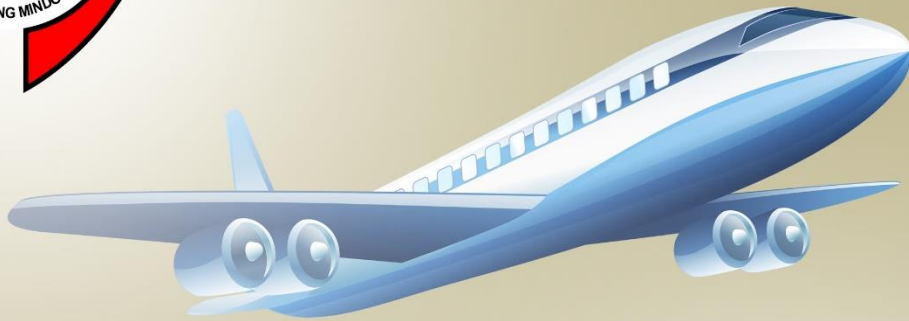

PINAMALAYAN CITY,
the Central Trading Hub of Oriental Mindoro
and the rest of MIMAROPA
demonstrating a robust investor- and
tourist-centered economy
with diversified agro-industrial activities
anchored on sustainable growth
and social equity.





MISSION



To boost local economy

by providing dynamic investment opportunities and creating a conducive climate for tourism, livelihood and growth enterprises development while ensuring rational increase in agricultural production as well as promoting competitiveness in diversification of trading and industrial activities, sustained and governed by structures and mechanisms which allow redistributive measures.

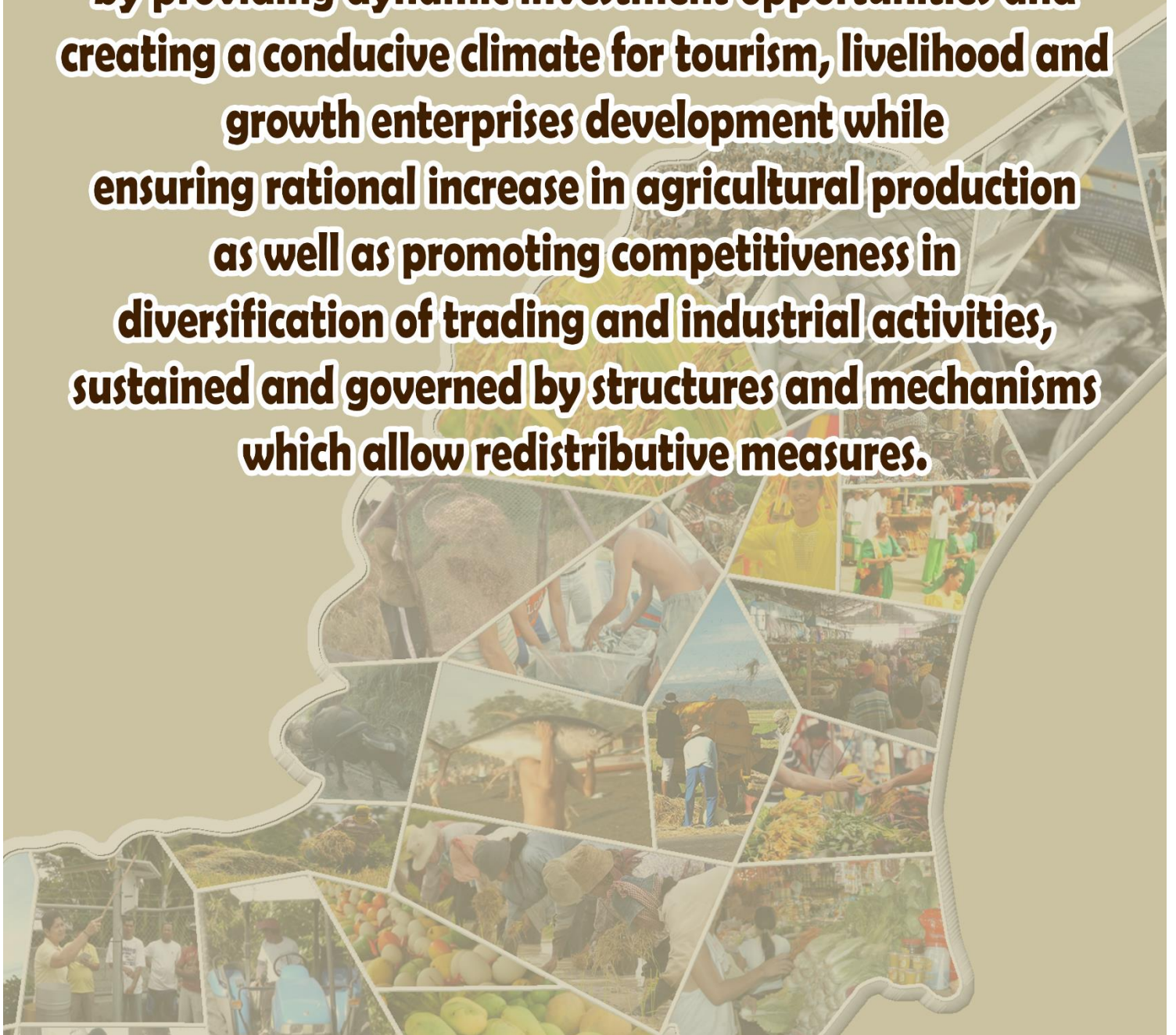



STRATEGIC THRUSTS AND DEVELOPMENT PRIORITIES

T

TRANSPARENCY, ACCOUNTABILITY AND GOOD GOVERNANCE

O

ORGANIZATIONAL DEVELOPMENT AND EMPOWERMENT

P

PEACE AND ORDER AND PUBLIC SAFETY

C

COMMUNITY INVOLVEMENT AND INTEGRATION

A

AGRICULTURE, TOURISM, HISTORY, CULTURE & ARTS AND ENVIRONMENTAL PROTECTION

R

REVENUE GENERATION AND LIVELIHOOD PROGRAMS

E

EDUCATIONAL AND TECHNICAL SKILLS DEVELOPMENT

S

SOCIAL PROGRAMS



CORE VALUES

Recognizing the vision of becoming the **CENTRAL TRADING HUB OF ORIENTAL MINDORO AND THE REST OF MIMAROPA** demonstrating a robust investor-and-tourist-centered economy, with diversified agro-industrial activities anchored on sustainable growth and social equity,

WE, public servants, commit ourselves to attain the vision of the **MUNICIPAL GOVERNMENT OF PINAMALAYAN** by living by the tenets of the following **CORE VALUES:**

RESPONSIBLE LEADERSHIP

ACCOUNTABILITY AND TRANSPARENCY IN GOVERNANCE

INNOVATIVE AND EXCELLENT SERVICE

NURTURERS OF FAITH AND PATRIOTIC IDEALS

BUILDERS OF POSITIVITY AND TEAM SPIRIT

OBJECTIVITY AND INTEGRITY OF PURPOSE

WELL-BALANCED ECOLOGY ADVOCATES





RINAMALAYAN

BRIEF PROFILE



MUNICIPAL OFFICIAL LOGO



**NATIONAL HISTORICAL INSTITUTE
MONUMENTS and HERALDRY DIVISION**

RISING SUN

Represents the glowing/bright future of the town.

RAINBOW

Symbolizes hope and prospect for progress and its discovery.

YELLOW DOT

Describes the geographical location of the Municipality of Pinamalayan

MAP AND TAMARAW

Denote Strength

COLOR GREEN

Stands for the youth; rich farmland

COLOR WHITE

Stands for justice and the road to progress.

COLOR BLUE

Stands for peace, calmness and the abundance of sea products.

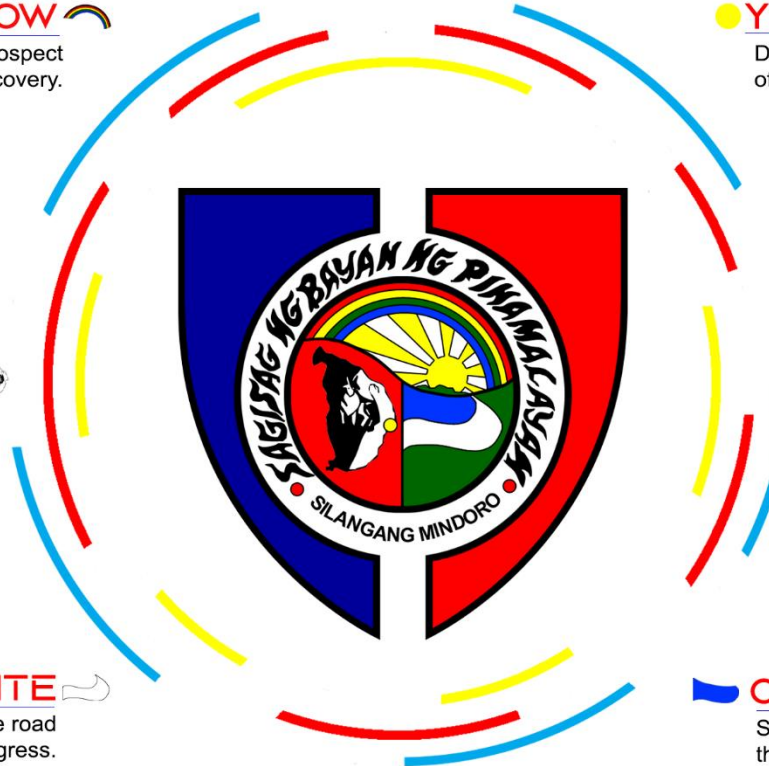

SHIELD

Derived from the provincial seal of Mindoro Oriental where the town is located; stylized caring/loving hands of its local executives; it also represents that Pinamalayan is a free and peaceful municipality.

Recommending Approval:

SERAFIN D. QUIASON
Chairman

OFFICE OF THE PRESIDENT
Approved by Authority of the
President :

LUIS C. LIWANAG II
Deputy Executive Secretary

March _____, 1993 File No. _____ Date _____

HISTORICAL BACKGROUND

The name of the town was said to be taken from the word “ipinamalay” which means to make aware or to show the way. According to an old story, early settlers of this town came from a group of adventurous transmigrants who encountered turbulent weather in the sea. They prayed to God Almighty for deliverance and guidance, whereupon, the weather cleared and a rainbow appeared on the horizon. The crew shouted “ipinamalay na” which means it was made known. They followed the direction of the rainbow believing that at its end lies a pot of gold and good fortune. They finally landed at what is now barangay Lumambayan and established the first settlement which they named Pinamalayan. They found good fortune in the new land which brought them prosperity because of the good soil and abundant resources.



LEGEND

On the other hand, some sources state that the name Pinamalayan came from the word “Pinagpalayan” which means “planted with rice”, for it was once a vast area planted with rice. Rice farming is an important source of livelihood of the municipality, up to this day. Since then, the place grew and became a town. However, during the entire 18th century, Pinamalayan was one of the coastal areas frequently attacked by Moro pirates. People were decimated and many fled to the interior for safety.

1800

Pinamalayan is one of the oldest towns in the province of Oriental Mindoro. Its territory once went as far as the old settlements of Sumagui and Anilao which are now part of the municipalities of Bansud and Bongabong, respectively. The towns of Pola and Gloria, now separate municipalities, were also former parts of the old domain. This was then organized as a permanent settlement in 1800's under the leadership of a gobernadorcillo.

APRIL 29, 1904

Under the American government, the towns of Pola and Bongabong were consolidated with Pinamalayan by virtue of Act 1155.



CREATION OF THE MUNICIPALITY

1888

In the year 1888, the territory of Pinamalayan included the settlements of Pola, Sumagui, and Anilao. At that time, the gobernadorcillo was Juan Morente, Jr., who assumed position until 1898 when the uprising against the Spanish government broke out. Morente Jr. joined the revolutionary forces as a captain then Juan Medina replaced him as the town head. When the Spaniards surrendered, Morente Jr. became governor of the province of Mindoro while Cornelio Nable was appointed as the municipal president.

JANUARY 12, 1912

Pola became an independent town. A major political change brought about by the American occupation was that the Municipal Council acted on the selection of a new town site through viva-voce voting in 1914.

1916

The seat of the Municipal Government was officially transferred from barangay Lumambayan to its present site.

HISTORICAL BACKGROUND

1919

Bongabong likewise regained its township status in March 1919 under Act 2824. The American planners made sure that the town is properly laid out according to a planning system that included wide, symmetrical roads with appropriate drainage facilities. It was also during this time that a big plaza was constructed adjacent to the municipal building. These turns of events made Pinamalayan as a model in town planning to all the municipalities in Oriental Mindoro. Moreover, the repeated territorial reorganizations signify the role of Pinamalayan as a major political and economic center in the southern part of Oriental Mindoro way back in the latter years of the Spanish regime up to the American rule. Administrative orders regulating secular activities in the settlements of neighboring towns were once sent from Pinamalayan. Thus, this gives the municipality considerable advantages in terms of trade, infrastructure development, social facilities, and even political accommodations at the onset of the century.



1942

When the Japanese occupied Mindoro in 1942, Dr. Abelardo Bunag, then mayor, joined the underground movement. The Japanese then appointed Carlos Aguilucho as mayor, followed by Manuel Medina. Then, the Americans returned around January 15, 1945.



1964

In 1964, Gloria became an independent town. From 1947 to 1990 under various administrations, Pinamalayan grew steadily to become the progressive town that it is today.



Table HB-1 presents the local chief executives from year 1901 to present. Throughout history, the municipality had 32 municipal mayors.



Table HB-1. Local Chief Executives of Municipality of Pinamalayan, Oriental Mindoro, Year 1901-2019

	Name of LCE	Term of Office		Name of LCE	Term of Office
1	Cornelio Nable	1901-1902	17	Manuel Medina	1943-1945
2	Juan Aguilucho	1902-1903	18	Tomas Villamin	1946-1947
3	Vicente Dominguez	1903-1904	19	Dominador Madrid	1948-1951
4	Florencio Morente	1905-1906	20	Remegio Pio Baldos	1952-1955
5	Juan Morente, Jr.	1907-1912	21	Dominador Madrid	1956-1967
6	Jesus Dominguez	1913-1915	22	Santos Frane (OIC)	1967-1968
7	Jose Benitez	1915-1916	23	Jose Reynaldo Morente, Jr.	1968-1972
8	Elias Semilla	1916-1919	24	Crispulo La Rosa	1973-1979
9	Carlos Aguilucho and Francisco Luarca	1925-1928	25	Emilina Baldoz	1980-1986
26			Reynaldo Mambil	1986-1987	
11	Anaceto Villamin	1928-1929	27	Lydia Olea (OIC)	1988
12	Conrado Morente	1929-1934	28	Manuel O. Morente, Sr.	1988-1995
13	Felipe Venturanza	1934-1938	29	Wilfredo L. Hernandez, Sr.	1995-2004
14	Carlos Aguilucho	1938-1940	30	Aristeo V. Baldos, Sr.	2004-2007
15	Abelardo Buñag	1941-1942	31	Wilfredo L. Hernandez, Sr.	2007-2016
16	Carlos Aguilucho	1942-1943	32	Aristeo A. Baldos, Jr.	2016-present

Source: Municipal Planning and Development Office

SIGNIFICANT DEVELOPMENTS IN THE MUNICIPALITY







































PINAMALAYAN FIRST CLASS MUNICIPALITY

BY VIRTUE OF DOF DEPARTMENT ORDER NO. 20-05
IMPLEMENTED BY BILG MEMORANDUM CIRCULAR NO. 01-M (43)-05
ISSUED ON JANUARY 31, 2006



GEO-PHYSICAL ENVIRONMENT

URBAN BARANGAYS				RURAL BARANGAYS						
COASTAL BARANGAYS	 WAWA	 MARFRANCISCO	 ZONE I	 PAPANDAYAN	 LUMAMBAYAN	 GUINHAWA	 BANILAD	 RANZO	 QUINABIGAN	 PILI
	 ZONE II	 ZONE III	 ZONE IV	 CACAWAN	 ANOLING	 BACUNGAN	 BANGBANG	 BULI	 CALINGAG	 DEL RAZON
	 STA. RITA				 INCLANAY	 MALAYA	 MALIANGCOG	 MANINGCOL	 MARAYOS	 NABUSLOT
					 PAGALAGALA	 PALAYAN	 PAMBISAN MALAKI	 PAMBISAN MUNTI	 PANGGULAYAN	 ROSARIO
				 SABANG	 STA. ISABEL	 STA. MARIA	 STO. NIÑO			



PINAMALAYAN 37 BARANGAYS



GEO-PHYSICAL ENVIRONMENT

EXISTING GENERAL LAND USE

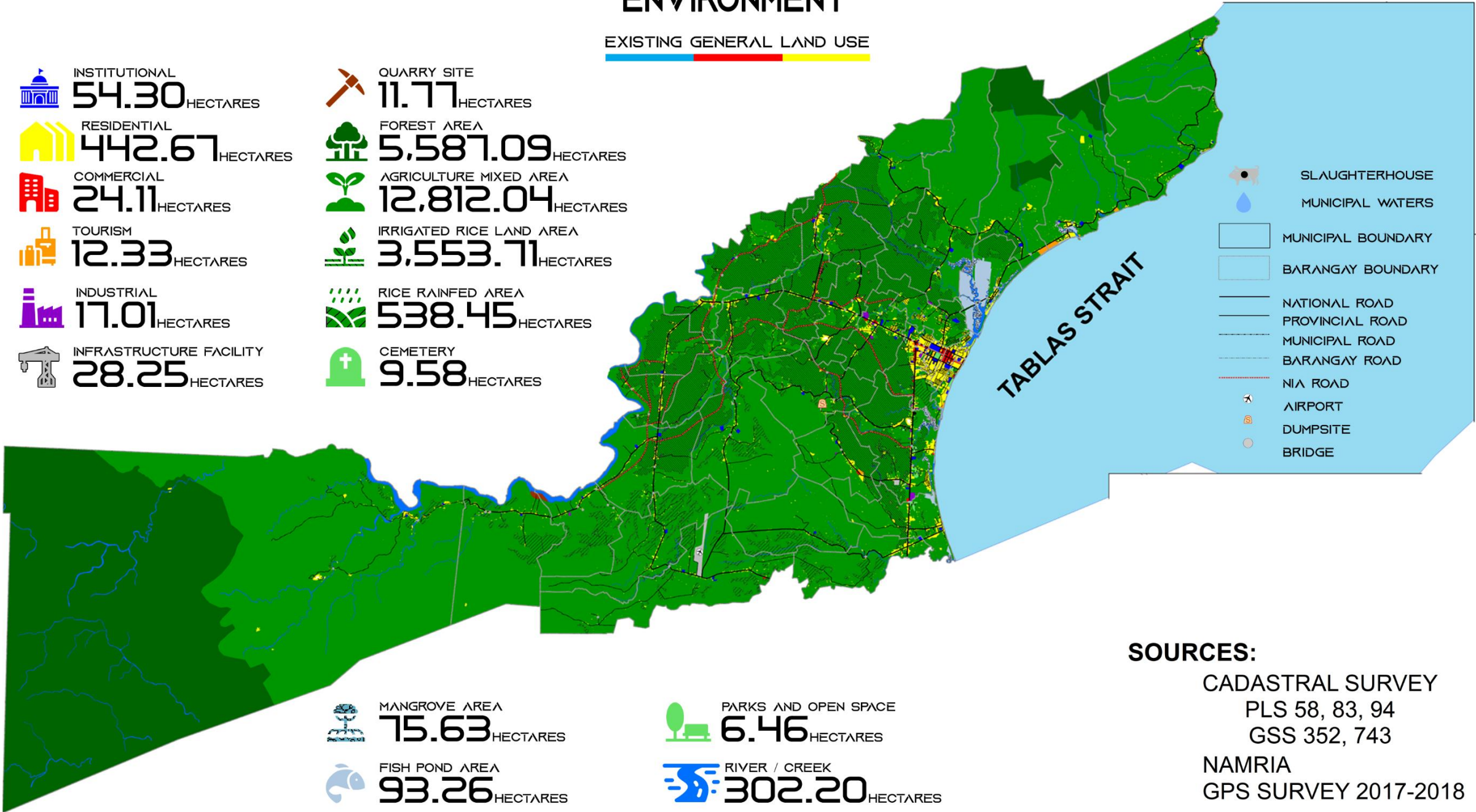
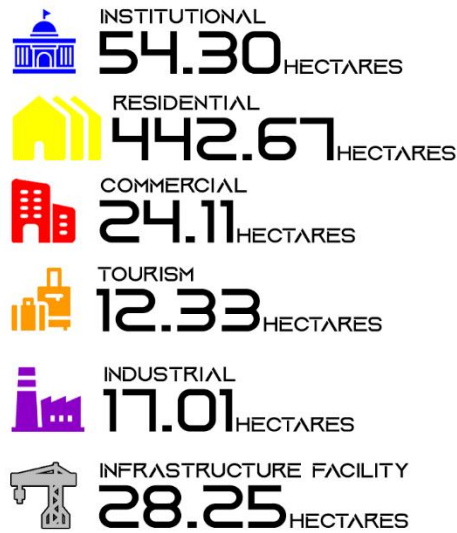

- SLAUGHTERHOUSE
- MUNICIPAL WATERS
- MUNICIPAL BOUNDARY
- BARANGAY BOUNDARY
- NATIONAL ROAD
- PROVINCIAL ROAD
- MUNICIPAL ROAD
- BARANGAY ROAD
- NIA ROAD
- AIRPORT
- DUMPSITE
- BRIDGE

SOURCES:
 CADASTRAL SURVEY
 PLS 58, 83, 94
 GSS 352, 743
 NAMRIA
 GPS SURVEY 2017-2018

DEMOGRAPHY

DEMOGRAPHIC SIZE

TOTAL POPULATION
90,383
SOURCE: 2020 CPH PSA



CRUDE BIRTH RATE
6.35
SOURCE: 2021 MHO



GROWTH RATE
1.01
SOURCE: 2020 CPH PSA



CRUDE DEATH RATE
4.20
SOURCE: 2021 MHO

DEMOGRAPHIC DISTRIBUTION



NUMBER OF HOUSEHOLDS
21,322
SOURCE: 2020 CPH PSA



HOUSEHOLD SIZE
4 PERSONS
IN EVERY HOUSEHOLD
SOURCE: 2020 CPH PSA



POPULATION DENSITY
3 PERSONS
PER HECTARE
SOURCE: 2020 CPH PSA & MAssO

POPULATION
PROJECTION



97,949 YEAR
2028
116,197 YEAR
2045



HOUSEHOLD
PROJECTION

22,779
27,023

POPULATION COMPOSITION

SCHOOL GOING POPULATION
32,710
SOURCE: 2018 CBMS 3RD ROUND SURVEY



WORKING AGE
48,863
SOURCE: 2018 CBMS 3RD ROUND SURVEY

LABOR FORCE
26,280
SOURCE: 2018 CBMS 3RD ROUND SURVEY



YOUNG DEPENDENT POPULATION
24,394
SOURCE: 2018 CBMS 3RD ROUND SURVEY

OLD DEPENDENT POPULATION
4,701
SOURCE: 2018 CBMS 3RD ROUND SURVEY



OVERSEAS FILIPINO WORKERS
1,446
SOURCE: 2018 CBMS 3RD ROUND SURVEY

POPULATION CHARACTERISTICS

REGISTERED VOTERS
50,248
SOURCE: 2021 COMELEC



MANGYAN POPULATION
1,033
SOURCE: 2018 CBMS 3RD ROUND SURVEY

MOTHER TONGUE
98.84%
TAGALOG



RELIGION
90.02%
ROMAN CATHOLIC

4.16%
OTHER LANGUAGE
SOURCE: 2018 CBMS 3RD ROUND SURVEY

9.98%
OTHER RELIGIONS
SOURCE: 2018 CBMS 3RD ROUND SURVEY

POVERTY SITUATION



POVERTY THRESHOLD
42.90%
SOURCE: 2018 CBMS 3RD ROUND SURVEY



FOOD THRESHOLD
29.99%
SOURCE: 2018 CBMS 3RD ROUND SURVEY



FOOD SHORTAGE
1.61%
SOURCE: 2018 CBMS 3RD ROUND SURVEY

SOCIAL SECTOR

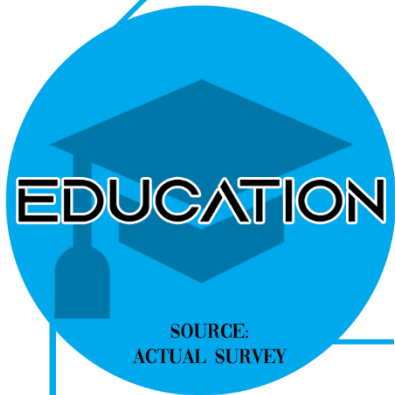

TOTAL NUMBER OF SCHOOLS		TOTAL NUMBER OF ENROLMENT	
KINDERGARTEN	40	KINDERGARTEN	5,343
ELEMENTARY	40	ELEMENTARY	8,074
JUNIOR HIGH SCHOOL	18	JUNIOR HIGH SCHOOL	7,805
SENIOR HIGH SCHOOL	15	SENIOR HIGH SCHOOL	5,622
TERTIARY	5	TERTIARY	6,462

STUDENT - TEACHER RATIO		STUDENT - CLASSROOM RATIO	
ELEMENTARY	25:1	ELEMENTARY	27:1
JUNIOR HIGH SCHOOL	23:1	JUNIOR HIGH SCHOOL	40:1
SENIOR HIGH SCHOOL	17:1	SENIOR HIGH SCHOOL	29:1

LITERACY RATE
96.83%
SOURCE: 2018 CBMS 3RD ROUND SURVEY

NUMBER OF HOSPITALS
4
SOURCE: 2022 MHO

NUMBER OF HEALTH CENTERS
38
SOURCE: 2022 MHO

NUMBER OF PUBLIC DOCTORS
17
SOURCE: 2022 MHO

HIGHEST LEADING CAUSES OF MORTALITY
CARDIO VASCULAR ARREST
SOURCE: 2022 MHO

HIGHEST LEADING CAUSES OF MORBIDITY
ACUTE RESPIRATORY INFECTION
SOURCE: 2022 MHO



MALNOURISHED CHILDREN
1,783
SOURCE: 2018 MHO

HOUSEHOLDS WITHOUT ACCESS TO SANITARY TOILET FACILITY
10.08%
SOURCE: 2018 CBMS 3RD ROUND SURVEY

COVID DATA
SOURCE: 2021 MHO

CASES RECOVERED
310
DEATH
4

SOCIAL SECTOR

HOUSEHOLDS WHO ARE INFORMAL SETTLERS

7.2%

SOURCE: 2018 CBMS 3RD ROUND SURVEY



HOUSEHOLDS WHO ARE LIVING IN MAKESHIFT HOUSING

1.67%

SOURCE: 2018 CBMS 3RD ROUND SURVEY

HOUSING

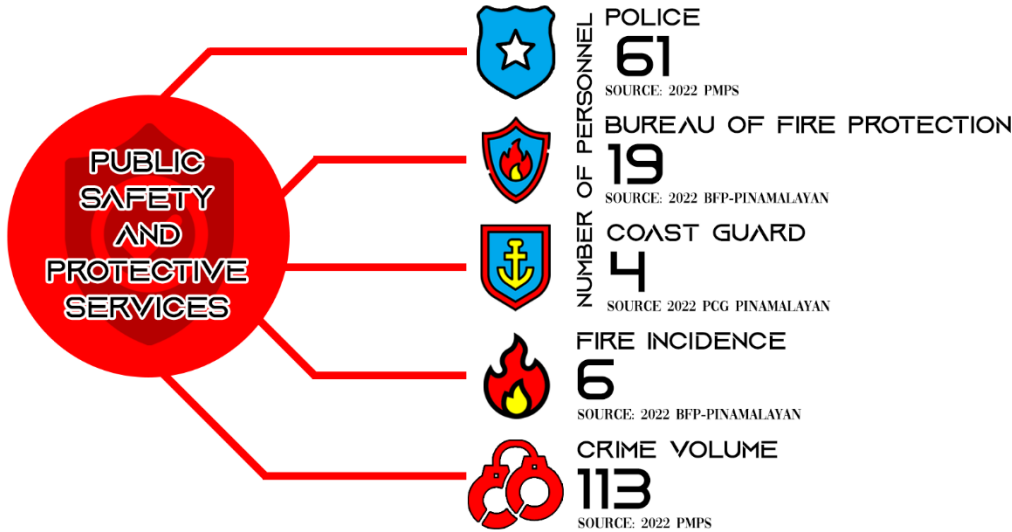

ECONOMIC SECTOR

AGRICULTURE

SOURCE: 2022 MAGO



TOTAL AGRICULTURAL AREAS

9,009 HECTARES



LIVESTOCK

37,711



NUMBER OF FARMERS

7,682



NO. OF LIVESTOCK FARMERS

3,305

COMMERCE AND TRADE

SOURCE: 2021 BPLD



PRIMARY ACTIVITIES

25
Agriculture/Hunting/Forestry
Fishing
Mining/Quarrying



SECONDARY ACTIVITIES

156
Manufacturing
Electricity, Gas, & Water Supply
Construction



TERTIARY ACTIVITIES

2,273
Wholesale/Retail
Hotel/Lodging
House & Restaurants
Transport/Storage & Communications
Financial Intermediation, Real Estate, Renting
Educational Institution, Hospital/Clinic



REVENUE FROM BUSINESS ESTABLISHMENT

PHP 17,765,478.53

TOURISM

SOURCE: 2022 THCAU



NUMBER OF EXISTING TOURISM ESTABLISHMENTS

34



VISITOR ARRIVAL

35,087

INFRASTRUCTURE AND UTILITIES SECTOR

TRANSPORTATION

NUMBER OF PUBLIC LAND TRANSPORT VEHICLES
SOURCE: 2022 BPL0

TRICYCLE
2,708

MULTICAB
44

VAN
62

TOTAL ROAD LENGTH
289 KM
SOURCE: 2022 MEO

NUMBER OF BRIDGES
20
SOURCE: 2022 MEO

NUMBER OF TRANSPORT TERMINALS
6
SOURCE: 2022 MEO

NUMBER OF TODA ASSOCIATION
29
SOURCE: 2022 BPL0

OTHER TRANSPORT FACILITIES

AIRPORT
1

SEAPORT
1

POWER

POWER PLANT
9.7 MW DIESEL POWERED (1)

HOUSEHOLDS WITH ACCESS TO ELECTRICITY
91.06%
SOURCE: 2018 CBMS 3RD ROUND SURVEY

HOUSEHOLDS WITH ACCESS TO IMPROVED WATER SOURCE
20.83%
SOURCE: 2018 CBMS 3RD ROUND SURVEY

INFORMATION AND COMMUNICATION

RADIO STATION
2

TELEPHONE SERVICES PROVIDER
2

POSTAL SERVICES
2

COMMUNICATION TOWERS
17

INTERNET SERVICES PROVIDER
3

INSTITUTIONAL SECTOR

ORGANIZATION AND MANAGEMENT

ELECTIVE OFFICIALS
12

PERMANENT
235

TEMPORARY
3

CO-TERMINUS
4

JOB ORDERS
303

CONTRACT OF SERVICE
27

FISCAL MANAGEMENT

TOTAL INCOME
PHP 410,934,174.66

TOTAL EXPENDITURE
PHP 370,819,021.00

DEVELOPMENT LEGISLATION

ORDINANCES
142

RESOLUTIONS
1,162

NARRATIVE DESCRIPTION:

The Municipal Government of Pinamalayan has been processing all transactions manually over the past years. This manual process served as the comfort zone of most of the employees, especially those who have been in government service for a long time which is also one of the main reasons why there is a digital divide among the employees. However, the lack of a centralized information system can have several negative consequences for an organization. Files and other important data may be restored to different locations which can be more difficult to manage and maintain, hence may result in inconsistency and inaccuracy of data. Other departments may develop and use their own systems which other departments have no access to. A lack of uniform transactions may result in difficulty in analyzing data from multiple sources.

Technology contributes a significant role as we are in the era of the digital revolution. Once the physical structure of the ICT building has been established and has enough resources and manpower, one of the proposed projects of the ICT is the Centralization of the Information System. In a centralized information system, all data will be collected and will be consolidated into a single location. This will establish uniform transactions in municipal government. The ICT unit will be the central location in the centralization of the local area network and centralization of the information system.

Additionally, the centralization of information system also enhances the security of the data since all the data will be stored in a single location. This can help to prevent unauthorized access to sensitive information. Each module may only be accessed by the concerned municipal office and what level of access they will have. This will not only benefit the smooth transaction in each office but also will be a great opportunity to hire trained IT professionals that will enhance the ICT services.

Further, in organizations where data is generated from multiple sources and it is crucial to have a single, reliable source of information, centralized information systems are frequently used. Establishing a centralized information system requires careful planning and execution. In order to implement the said project, requires a financial budget for the resources and for the maintenance of the proposed centralized information system. The support and transparent communication between municipal offices will also greatly benefit the development and implementation of the proposed project.

VITAL FACTS AND FIGURES:

PERSONNEL/STAFFING COMPLEMENT			
Status of Appointment	Number		
	Male	Female	Total
Appointive/Elective	0	0	0
Co-terminous	0	0	0
Permanent	1	0	1
Temporary	0	0	0
Contractual/Consultants	0	0	0
Contract of Service	1	1	2
Job Order	2	0	2
Total Workforce	4	1	5

AGE			
Age Range	Number		
	Male	Female	Total
20-29	1	1	2
30-39	2	0	2
40-49	0	0	0
50-59	1	0	1
60 and above	0	0	0
Total	4	1	5

EMPLOYMENT STATUS			
Status	Number		
	Male	Female	Total
Permanent	1	0	1
Temporary	0	0	0
Elective	0	0	0
Co-Terminous	0	0	0
Contractual	0	0	0
Casual	0	0	0
Job Order	2	0	2
Contract of Service	1	1	2
Total	4	1	5

CATEGORIES OF POSITION			
Status of Appointment	Total		
	Male	Female	Total
Career	0	0	0
Non-career	1	0	1
Total Workforce	1	0	1

HIGHEST EDUCATIONAL ATTAINMENT			
Educational Attainment	Number		
	Male	Female	Total
Elementary Level/Graduate	0	0	0
Secondary Level/Graduate	0	0	0
Vocational/Associate Course	0	0	0
College Undergraduate	0	0	0
Bachelor's Degree	4	1	5
With Earned Units/Masters Undergraduate	0	0	0
Masteral Degree	0	0	0
Doctoral Degree	0	0	0
Total	4	1	5

LEVEL OF POSITION			
Level	Number		
	Male	Female	Total
1st Level	1	0	1
2nd Level	0	0	0
Executive Management/Managerial	0	0	0
.CES	0	0	0
.Non-CES	0	0	0
.Elective	0	0	0
Total	1	0	1

INDIGENOUS			
Status of Appointment	Total		
	Male	Female	Total
Appointive/Elective	0	0	0
Co-terminous	0	0	0
Permanent	0	0	0
Temporary	0	0	0
Contractual/Consultants	0	0	0
Contract of Service	0	0	0
Job Order	0	0	0
Total Workforce	0	0	0

SALARY GRADE			
Salary Grade	Number		
	Male	Female	Total
1	0	0	0
2	0	0	0
3	0	0	0
4	0	0	0
5	1	0	1
6	0	0	0
7	0	0	0
8	0	0	0
9	0	0	0
10	0	0	0
TOTAL	1	0	1

JOB/FUNCTIONAL CLASSIFICATION OF OFFICIALS AND EMPLOYEES			
Classification	Number		
	Male	Female	Total
Key	1	1	2
Technical	2	0	2
Support	0	0	0
Administrative	1	0	1
TOTAL	4	1	5

NUMBER OF YEARS IN PUBLIC SERVICE			
Years in Public Service	Number		
	Male	Female	Total
Less than 1 year	1	1	2
1-10 yrs	2	0	2
11 - 20 yrs.	0	0	0
21-30	1	0	1
31-40	0	0	0
41 and above	0	0	0
Total	4	1	5

Existing Applications

Department/ Office	Application System	Purpose
Office of the Municipal Mayor	Microsoft Excel Microsoft Word	Used to keep track of important records of the municipality (Policies, Programs, Budget)
Office of the Vice Mayor (Sangguniang Bayan Office)	Legislative Tracking System	Used to track all the resolutions and ordinances that need to be passed
		Used to record all the resolutions and ordinances passed
Municipal Administrator's Office	Microsoft Excel	Used to manage the day-to-day operations of the government
Business Permit and Licensing Office (BPLO)	Electronic Business and Licensing System	Used to generate business permits electronically
		Used to compute taxes and regulatory fees
		Used to automatically communicate stakeholder processing requirements to concerned offices
Municipal Planning and Development Office	GIS	Use for map generation purposes
	CBMS	Use to ensure the development of programs meet the needs of the community they
	MPDO Archive	Used to archive all paper documents
Municipal Budget Office	Microsoft Excel	Used to create and track budgets
	Microsoft Word	
Municipal Treasury Office	iTAX	Used to encode incoming and outgoing taxes
	Cash Receipt System	Used for real property tax statement issuance and RPT payment collection
		Used for O.R. issuances
Municipal Assessor's Office	iTax	Used to record all real properties for assessment purposes
	Geographic Information System (GIS)	Used to store digital tax map of LGU
Municipal Engineering Office	AutoCAD and other 3D Modelling Software	Used to create CAD files for drafting architectural designs of proposed infrastructure
Municipal Accounting Office	Microsoft Excel	Used to record financial transactions
Municipal Civil Registry Office	Civil Registry Information System	Used to keep track of all LGU births, deaths, and marriages
Human Resource and Management Office	Human Resource Management Information System	To manage human resources information and processes
		To provide HR employees with real-time access to employee data and performance metrics

Existing Hardware Inventory per Municipal Office as of 2021

Department	Desktop	Laptop	Printer	Scanner	Platter Machine	Copier Machine	UPS	AVR	Server	Switch/ Hub	Router	TV	Telephone	Projector	CCTV	Other Devices
Mayor's Office	7	5	11	0	0	1	4	5	0	0	1	3	1	1	0	
Municipal Administrator's Office	3	4	6	0	0	1	3	3	0	1	1	2	1	1		0
Municipal Vice-Mayor Office/Sangguniang Bayan	12	14	8	0	0	2	9	0	0	1	2	5	2	2	0	0
PLEB Office	1	1	1	0	0	0	1	1	0	0	0	1	1	0	0	0
Municipal Planning & Development Office	19	11	15	1	1	2	15	15	0	3	3	4	5	3	5	15
Municipal Health Office	9	4	6	0	0	0	1	5	0	1	1	3	0	0	0	0
Special Concern Office	3	2	2	0	0	1	1	1	0	0	1	1	1	0	0	0
Human Resource Management Office	7	5	8	0	0	1	6	2	1	2	2	2	1	1	4	0
General Service Division	5	3	3	0	0	1	1	4	0	0	1	1	1	0	0	0
Municipal Civil Registrar	6	0	6	0	0	1	4	3	0	1	1		1	0	0	0
Municipal Engineering Office	7	6	13	0	0	1	3	4	0	3	3	2	2	1	0	0
Municipal Treasury Office	1	1	3	0	0	0	2	2	0	1	1	0	0	0	0	0
Bids and Awards Committee																
Municipal Assessor's Office	5	0	6		0	0	0	1	0	1	1	0	1	0	0	
MENRO, Zoning and Motorpool Division	4	3	7	1	0	2	2	3	0	0	0	1	1	1	0	0
Municipal Social Welfare & Development Office	6	4	7	9	0	1	3	2	0	0	1	2	2	2	7	3
Municipal Agricultures Office	5	6	5	0	0	1	5	0	0	0	1	3	1	2	0	0
Municipal Accounting Office	14	9	14	3	0	1	13	0	1	1	2	1	2	0	0	0
Municipal Budget Office	12	5	8	0	0	1	13	10	0	1	2	2	5	2	8	0
Municipal Local Government Operations Office	3	2	3	0	0	0	2	3	0	0	1	0	1	2	0	1
Market Operations Department	4	1	6	0	0	1	2	3	0	1	1	4	1	1	52	4
Municipal Disaster Risk Reduction and Management Office	7	4	7	1	0	1	7	6	0	0	1	5	1	3	0	9
Slaughterhouse Operation Division	1	2	2	0	0	1	0	2		0	0	1	0	0	1	1
Permits and Licensing Division	8	6	8	0	0	1	3	3	0	1	1	2	2	1	0	0
Tourism, History, Culture and Arts Unit	3	2	3	0	0	0	1	3	0	0	1	1	0	1	0	2
Pinamalayan Tech4ED Center	8	4	5	0	0	1	5	9	0	2	2	0	1	2	0	0

Physical Inventory of Tech4ED Pinamalayan

PINAMALAYAN TECH4ED CENTER			
INVENTORY OF OFFICE EQUIPMENTS/FURNITURES/FIXTURES			
NUMBER	QUANTITY	UNIT	DESCRIPTION
1	1	unit	D-Link 8 Port 10/100 MBPS - white
2	1	pc	White Board
3	1	unit	Samsung 15" Monitor
4	5	pcs	Optical Mouse A4Tech
5	4	pcs	Keyboard A4Tech
6	1	set	Tool set
7	5	units	LG Led Monitor
8	1	unit	Lenovo Laptop
9	1	unit	D-Link Wireless N 150 Cloud router
10	1	unit	Desktop Computer - Samsung
11	3	units	Swivel Chair (Gray)
12	1	unit	Junior Chair (High Back)
13	1	unit	Executive Chair
14	1	pc	16 Port Hub
15	1	unit	Desktop Computer - Samsung
16	1	unit	Printer-Epson L210
17	5	units	APC UPS (600A)
18	1	pc	Wall Fan (Panasonic)
19	1	pc	Gang Chair (4 seaters)
20	2	pcs	Hard Disk Drive (SATA)
21	5	pcs	USB Flash Drive (8GB)
22	1	box	RJ45
23	1	unit	Flat Screen Monitor - Samsung
24	1	unit	Water Dispencer - Hanabishi
25	1	unit	TV Monitor - Hisense
26	1	unit	LED Monitor - Lenovo
27	1	unit	Desktop Computer - Samsung
28	1	unit	Desktop Computer
29	1	unit	Laptop - ACER
30	2	units	Desktop Computer - AOC
31	1	unit	Lasert Printer-Pro M102a
32	1	unit	Infrared Thermometer
33	1	unit	Photocopier Machine - Fuji Xerox
34	2	sets	Desktop Computer - N-vision, Meipark
35	2	units	Stan Fan - Asahi
36	1	unit	Desktop Computer - N-vision '19
37	1	unit	Printer- HP Laserjet 107a (white)
38	1	unit	Projector - Epson EB-2065
39	1	unit	Wi-Fi Duplex All in one printer-Epson L6270
40	1	unit	A3 Ink-Tank Printer - Epson L1300
41	1	unit	Desktop Computer - Samsung curved
42	1	unit	Laptop - Asus sn : MAN0CV20Y874437
43	1	unit	Projector - Acer P1276 DLP Projector (Black
44	1	unit	Projector - white
45	1	unit	Windows Type Aircon 2HP - Panasonic
46	1	unit	Printer - Epson L6290 - new
47	1	unit	Desktop Computer (YGT) - new
48	2	units	Laptop i5 - Acer - new

Organizational Structure

LEGEND:

Existing plantilla position

Vacant plantilla position

Funded/for creation in 2023

Non-regular Personnel

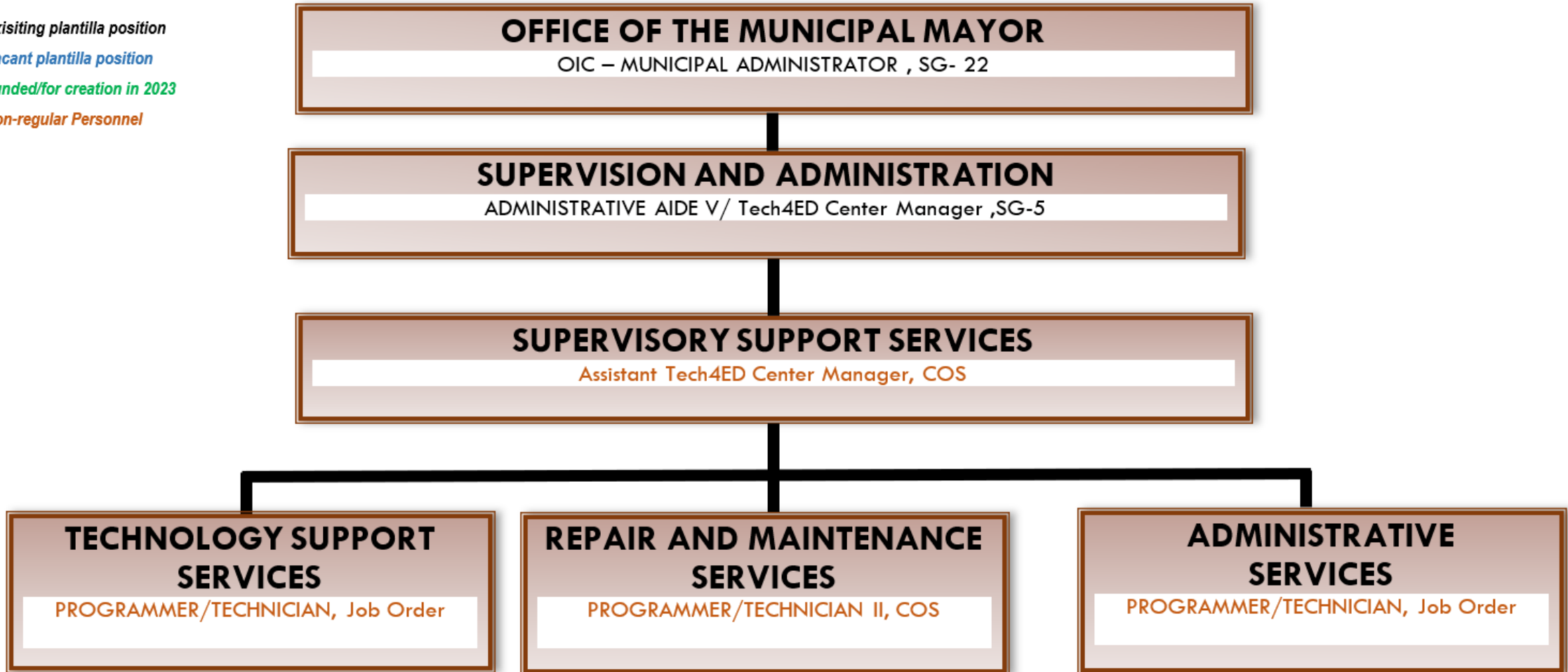

ANALYSIS MATRIX:

ISSUES/CONCERNS/OBSERVATIONS/TECHNICAL FINDINGS	STRATEGIES/RECOMMENDED INTERVENTIONS	POLICY OPTIONS/LEGISLATIVE MEASURES
Office of the Municipal Mayor	Document management and transactions are all paper-based. This makes the transaction complicated, slow, and inefficient	Implement a centralized system for the accuracy of data and inter-office communication
Municipal Administrator's Office		
BPLO and concerned offices	Related offices are not centralized; systems are not connected to required departments and do not support online payment for the transactions	Develop and implement a centralized information system that connects the required department
All concerned offices	No central point of control or authority	Implement a centralized local area network
Employees and Citizens	Providing information quickly, efficiently, and accurately	Provide Information Kiosk for accuracy of data

ISSUES AND CONCERNS	STRATEGIES/RECOMMENDED INTERVENTIONS		IMPLEMENTING OFFICE/DEPARTMENT	EXPECTED OUTCOMES/OUTPUTS			Source of Support/ Technical Assistance	Amount (in peso)
				2024	2025	2026		
KNOWLEDGE AND LEARNING								
1. Absence of a central point of control or management	1.1	Centralized Local Area Network (LAN) so all data and user access can be managed and monitored from a single location, making it easier to implement and enforce security measures.	Pinamalayan Tech4ED	Centralized Local Area Network (LAN) established			MO, OVM, MEO	2,500,000.00
	1.1.2	Cloud-based to access the data remotely through internet via cloud-based servers		Procured Cloud-based storage				30,000,000.00
Absence of central respiratory for system for storing and managing information within an organization	1.2	Centralized Information System to improve coordination and communication among different departments or locations				Centralized Information System established	MO, OVM, MEO	14,000,000.00
Inaccuracies and incompleteness of the information provided	1.3	Development of Information Database Kiosk to provide a self-service kiosk.				Information Database Kiosk Developed	MO, OVM, MEO	2,500,000.00
ENABLING POLICIES								
2. Lack of data security and privacy awareness	2.1	Data Security and Privacy awareness in compliance of R.A. Data Privacy Act of 2012	Pinamalayan Tech4ED	R.A. Data Privacy Act of 2012 implemented			MO, OVM	2,500,000.00
Absence of cloud computing solutions for government agencies	2.2	Create a more modern and efficient government that can better serve the needs of the people; Improve public services delivery and increase government efficiency		Circular No. 2017-002 and 2020-010 - Philippine Government's Cloud First Policy implemented			MO, OVM	14,000,000.00
Standardized set of building regulations	2.3	Buildings that will be constructed with safety measures		P.D. 1096 National Building Code of the Philippines Implemented			MO, OVM	2,500,000.00

Prepared by:

MR. EDCEL L. MARMOL
 Administrative Aide V/ Tech4ED Center Manager

Reviewed by:

ROSENIO A. TORIANO, EMP.
 Municipal Planning & Development Coordinator

Approved by:

MS. ZILDA M. MICIANO
 Municipal Budget Officer

HON. ARISTEO APASAN BALDOS, JR.
 Municipal Mayor

ICT Strategic Road Mapping

ICT STRATEGIC ROADMAP

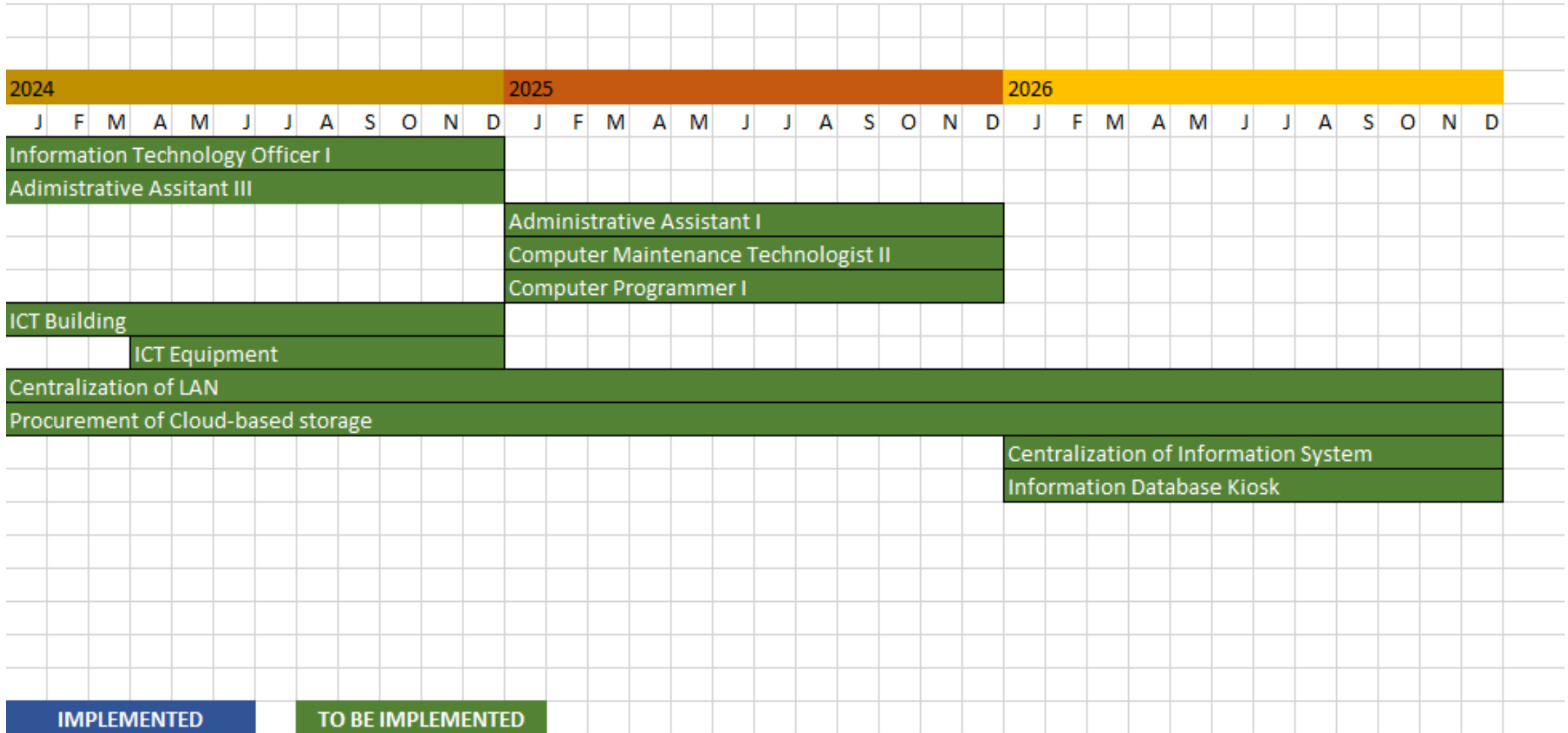

Proposed Centralized Network Diagram for the Municipal Compound

ONE SERVER FOR ALL OFFICES

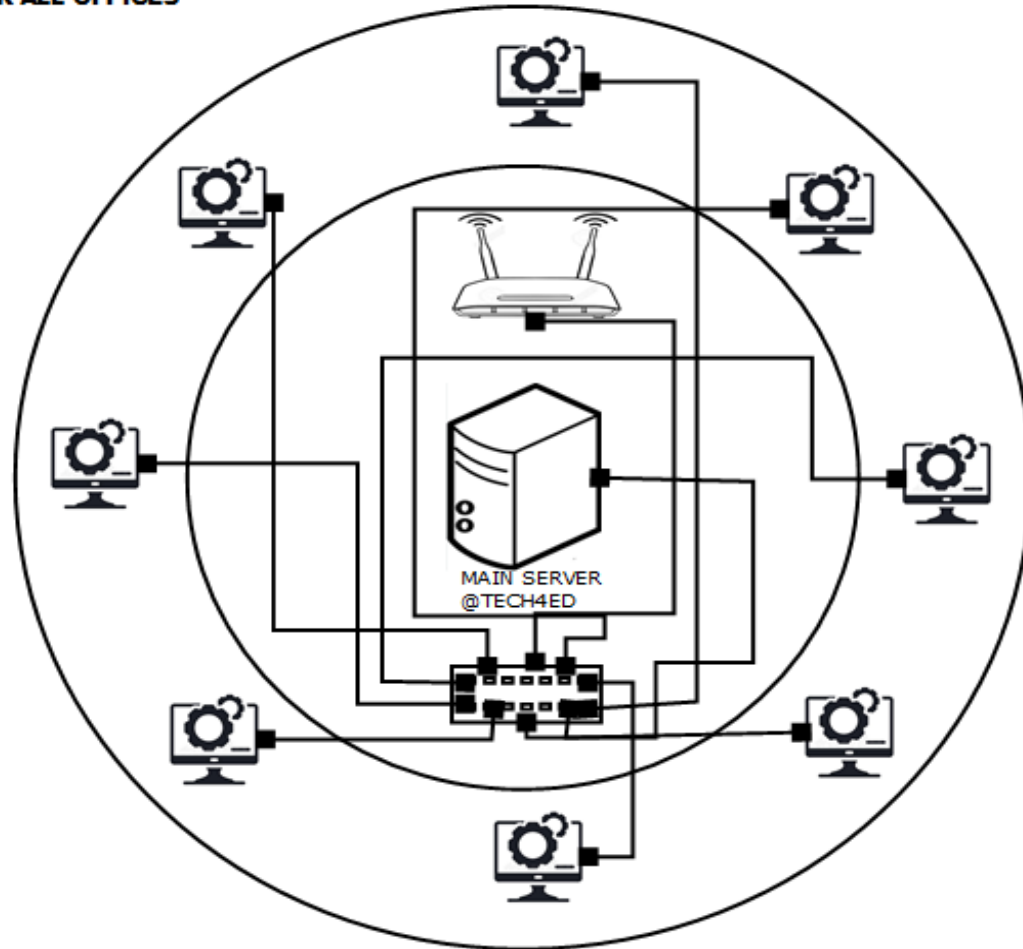

NETWORK DIAGRAM

Centralization of network systems involves the consolidation of the management and control of a network into a single location. In the context of offices, centralization of network systems would mean creating a single, unified network that serves all the offices in an organization.

Proposed Cloud Based System

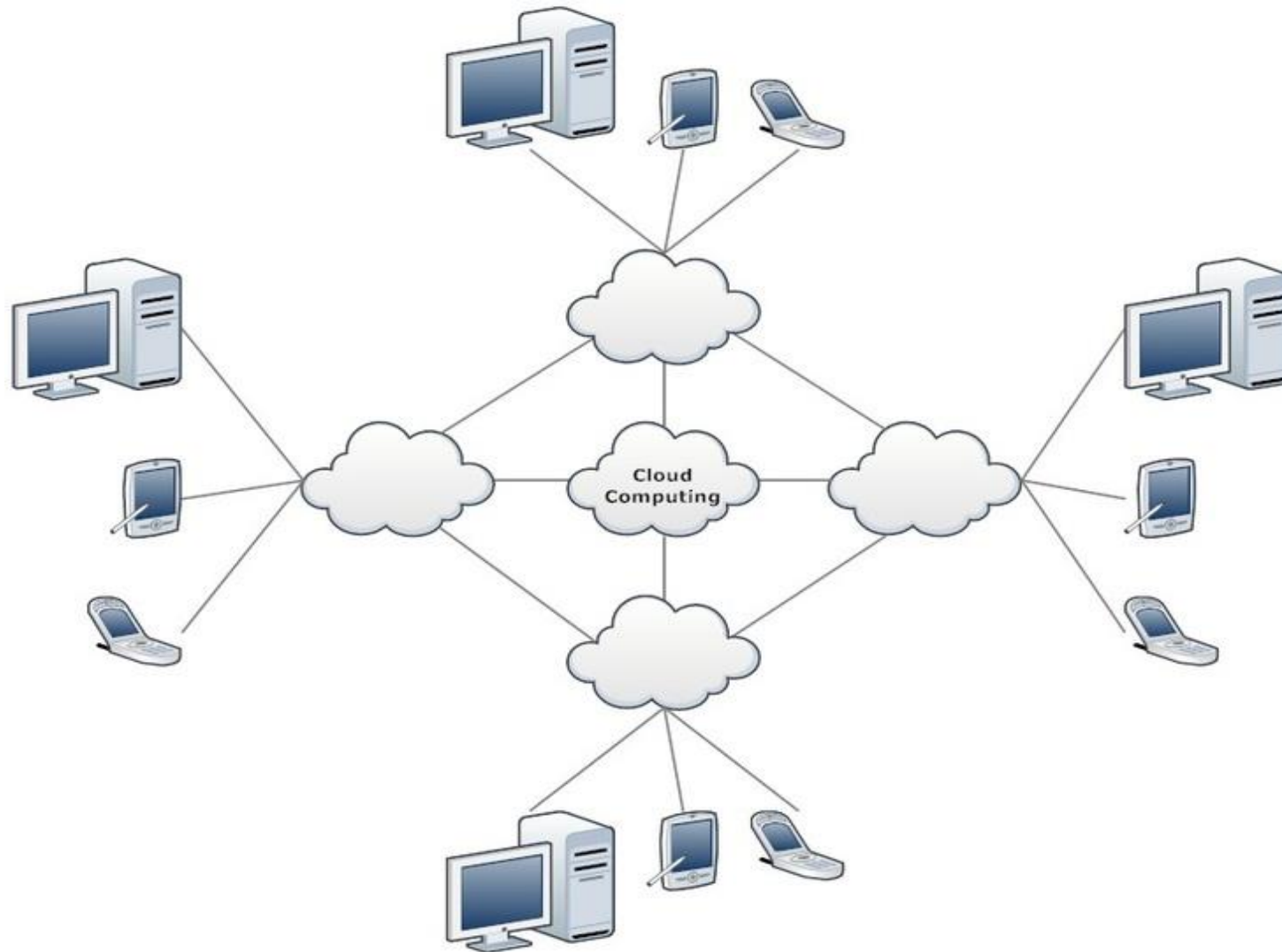

CLOUD BASED

EMPLOYEES OF LOCAL GOVERNMENT OFFICES CAN ACCESS AND STORE DATA REMOTELY THROUGH THE INTERNET VIA CLOUD-BASED. OFFICES NEED TO ACCESS THE SAME DATABASE, STORING IT IN CLOUD MAKES IT EASIER. ALL DATA IS STORED IN A CENTRAL LOCATION AND CAN BE ACCESSED BY AUTHORIZED USERS FROM ANYWHERE WITH AN INTERNET CONNECTION

Proposed Office Network Layout A

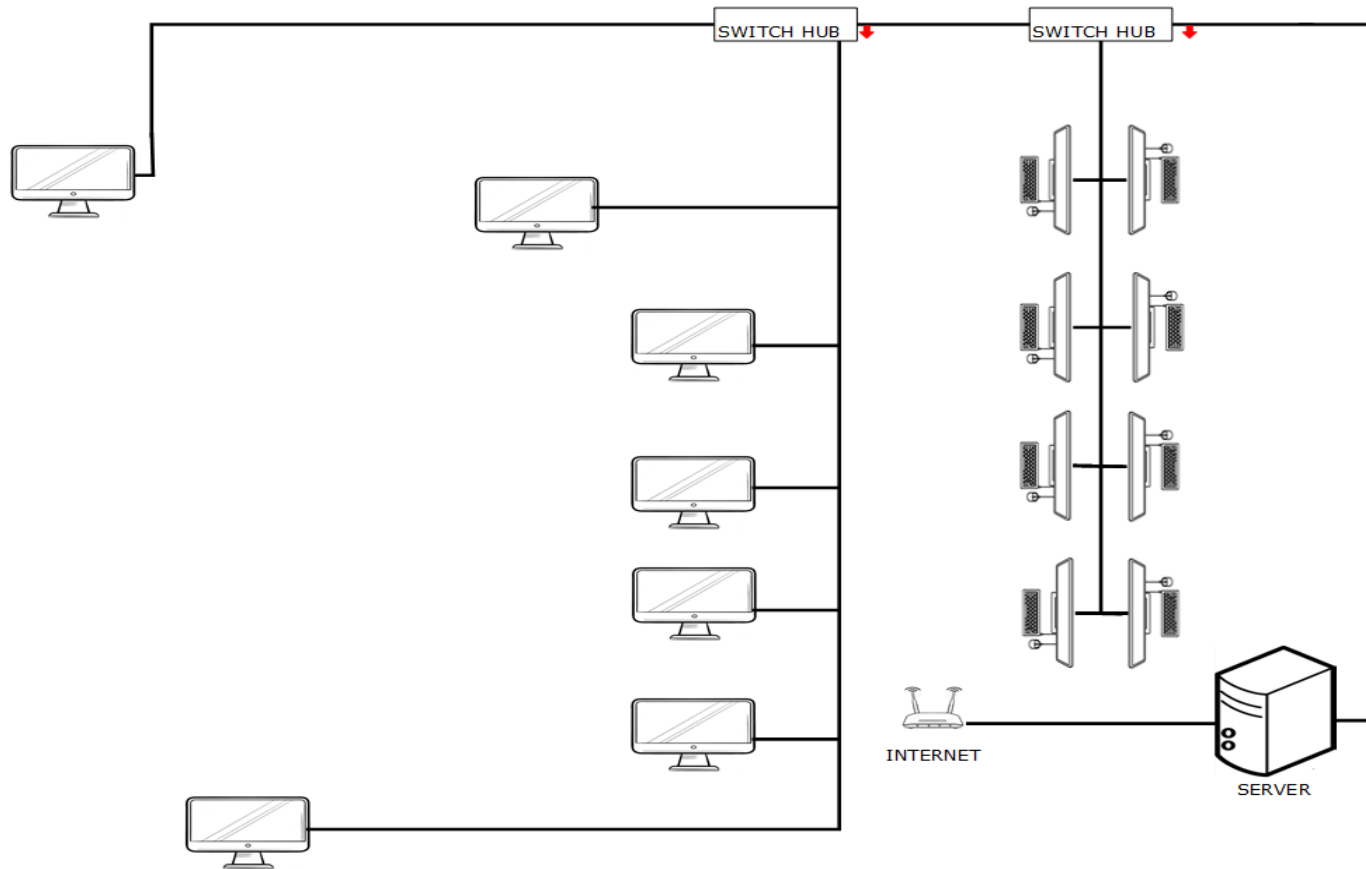

LOCAL AREA NETWORK

A LAN (Local Area Network) cable layout refers to the physical arrangement of the network cables that connect devices within a local network. In a LAN, cables are used to transmit data between devices such as computers, printers, and servers.

Proposed Office Network Layout B

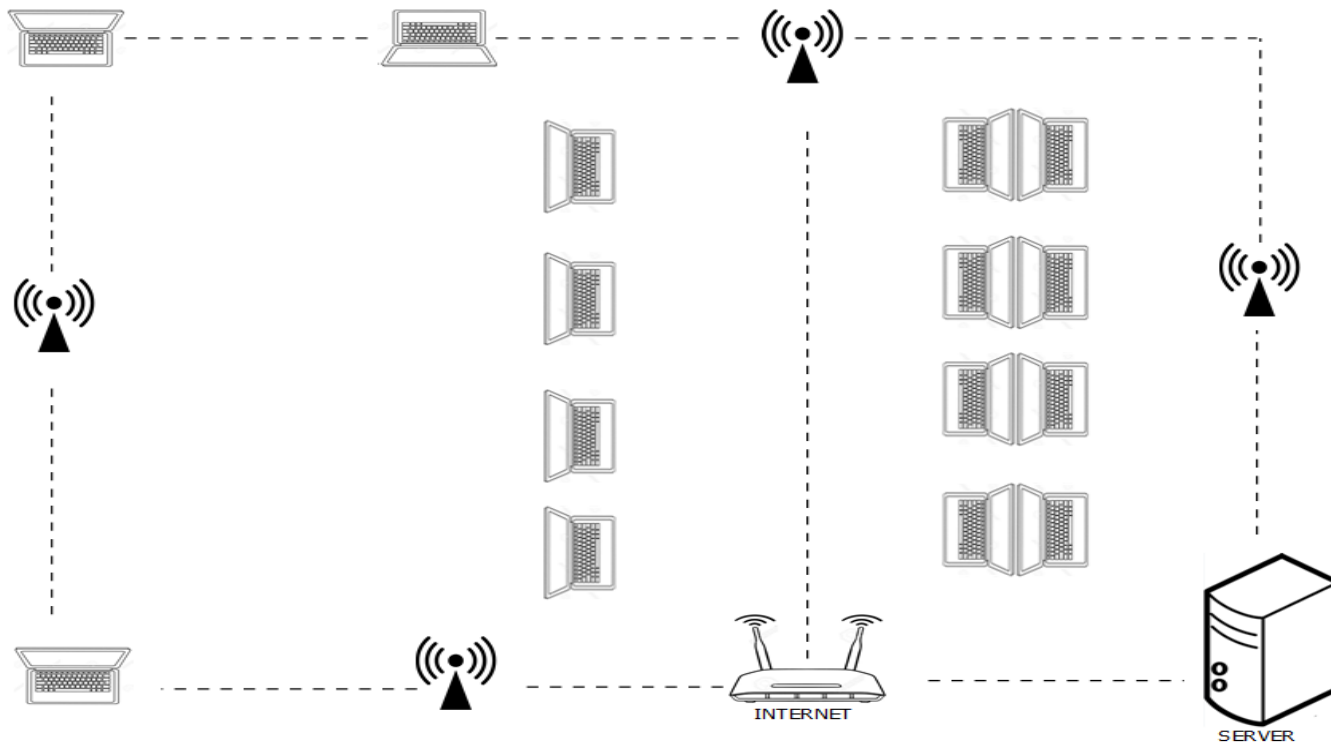

WIRELESS NETWORK

In a wireless connection layout, access points are used to transmit and receive data between devices. Access points are typically connected to a wired network, such as a LAN, and are strategically placed throughout a building or area to provide adequate coverage for wireless devices.

Proposed ICT Office Layout

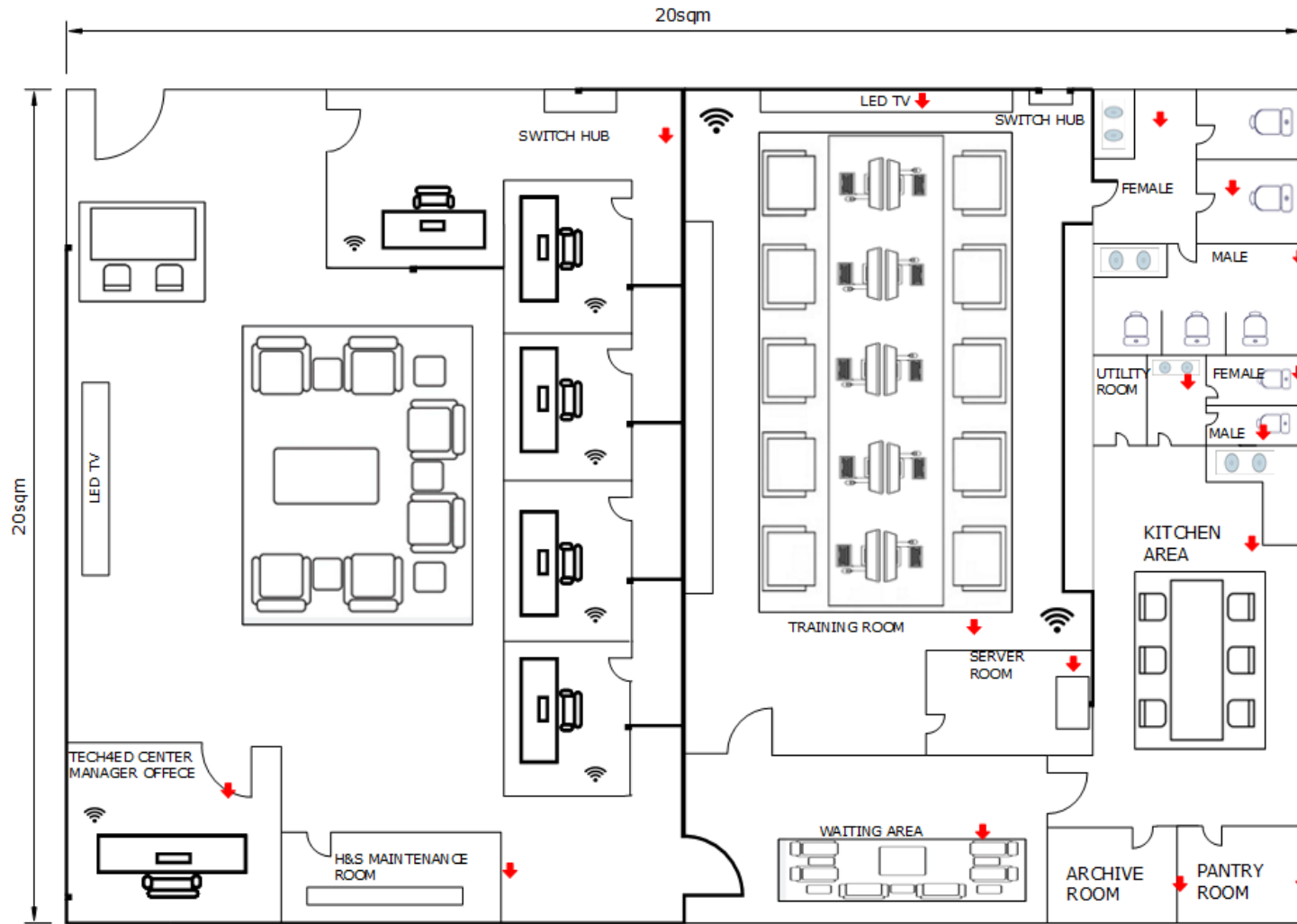

ICT OFFICE LAYOUT

Floor plan layouts are important in the design and construction of buildings, as they provide a clear and detailed view of the layout of a space. They can be used by architects, interior designers, builders, and property owners to visualize and plan the design of a building or space, and to ensure that it meets the requirements of its intended use.

Proposed Database Kiosk



DIGITAL BUILDING DIRECTORIES & WAYFINDING

Our self-service digital way finding kiosk offers a range of interactive features to help visitors navigate your city or venue. Some of the benefits include:

- Turn-by-turn directions to help guests find their destination
- Up-to-date information about events, schedules, and other important details
- Recommendations and information about local businesses and attractions
- Emergency alerts and directions to safe areas in case of an emergency
- Advertising opportunities when the kiosks are not in use

By providing this digital kiosk solution, you can enhance the visitor experience, improve safety, and boost local businesses.